



PICNIC TABLE

MATERIALS LIST

Lumber Required:

(2) 5/4 x 6 x 12 • (1) 5/4 x 6 x 8 • (1) 2 x 4 x 12 • (4) 2 x 8 x 12

Hardware Required:

(16) 3/8" x 3 1/2" Galvanized Carriage Bolts

(16) 3/8" Galvanized Flat Washers • 2 1/2" Deck Screws

CUT LIST

Table Top:

(5) 5/4 x 6" x 6'

(2) 2x4" x 28 1/2" (Notch bottom corners)

(1) 2x4" x 28 1/2"

Legs and Seats:

(4) 2x8" x 36" (Cut to 60° on each end)

(2) 2x8" x 61" (Notch bottom corners)

(4) 2x8" x 6'

(2) 2x4" x 28 1/4"

(Cut to 52° and 38° on ends)

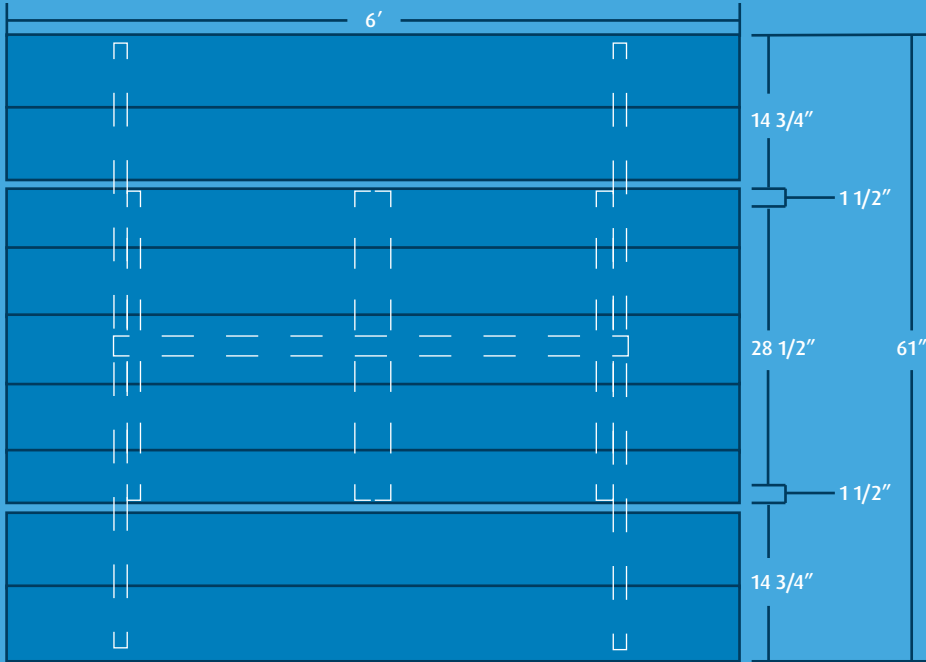

TOP VIEW

2 x 4 DIAGONAL BRACE REQUIRED



2 x 8 TABLE LEG (4 REQUIRED)

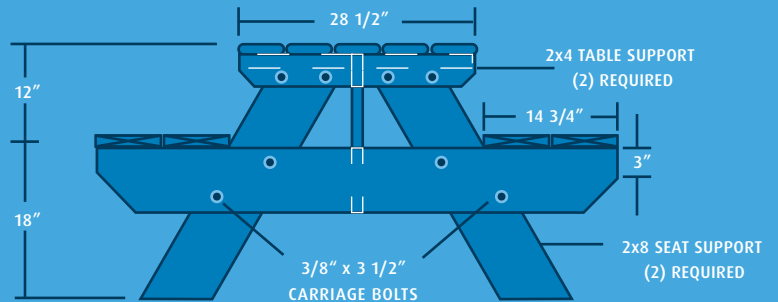
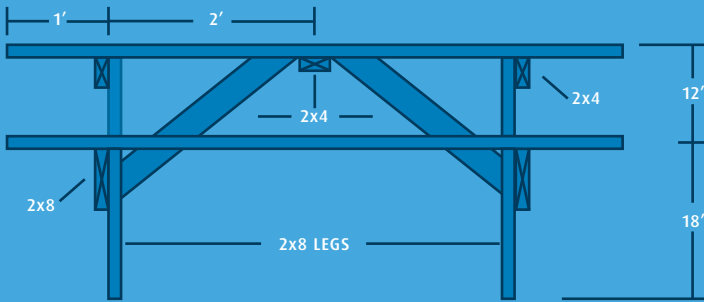
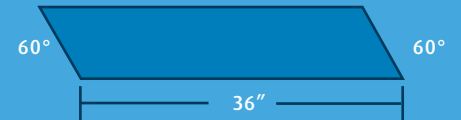

DIRECTIONS

Step 1: Cut pieces to length from the Cut List above

Step 2: Assemble table legs to seat and table supports as shown in drawing

Step 3: Drill and install galvanized carriage bolts

Step 4: Attach table top and seats to previously assembled table leg structures

Step 5: With table upside down, attach center 2x4 table top braces

Step 6: While holding leg assembly square to table top, attach 2x4 diagonal braces

Step 7: Turn table right side up and finish fastening the top and benches with deck screws

TOOLS NEEDED

